

# Titan GMS45

**Stainless Steel Fire Monitor Nominal flow 4,500 l/min**

- Simple and reliable design
- Low maintenance
- Most models available with lever or gearbox control
- Suitable for use where explosive atmospheres may be present

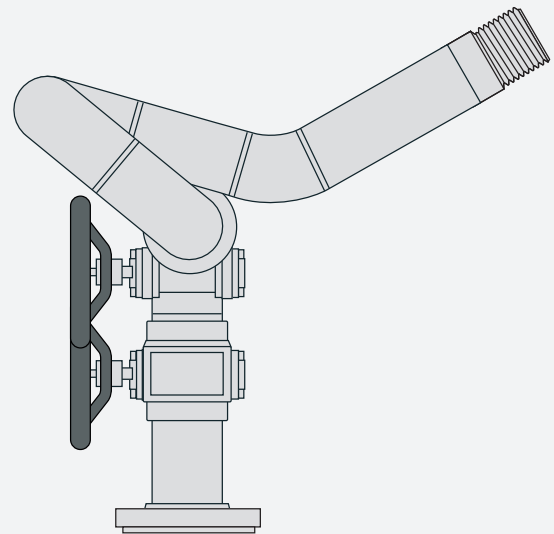

The Angus GMS45 stainless steel fire monitor is a simple and reliable design with non-reversible worm and wheel gearbox control in both the horizontal and vertical plane. Movement can be via hand wheels or chain wheels.

All GMS45 monitors are based on a proven low maintenance design developed over 20 years.

#### Monitor materials

Stainless steel body to AISI 16 / SS316  
Drain valve – brass

Material certification to EN 10204 3.1 is available on request

#### Bearing materials

Stainless steel (SS316) double ball race bearings on both axis

#### Gearbox specification

Fully enclosed non reversible worm and wheel

Worm and shaft material: bronze

Wheel material: stainless steel SS316

Worm bearings: twin ball race

Hand wheels: Cast iron

Chain drive available (CGMS45)

#### Inlet connection

Standard flange 4" ANSI 150 RF. (DIN and non standard flange options available)

#### Outlet connection

4" BSP M (NH optional)

#### Design pressure

Maximum working pressure 16 bar  
Hydraulic factory test pressure 24 bar

#### Performance

Pressure loss at 4,500 l/min 0.5 bar.  
(For pressure losses at other flow rates refer to the pressure loss graph.)

#### Weight

76 kg

#### Optional paint finish

Red Polyurethane

#### Movement

360° continuous rotation in the horizontal plane  
+90° / -45° movement in the vertical plane

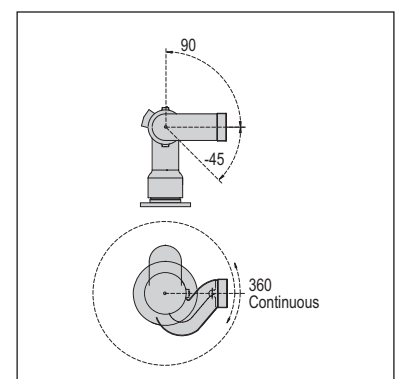
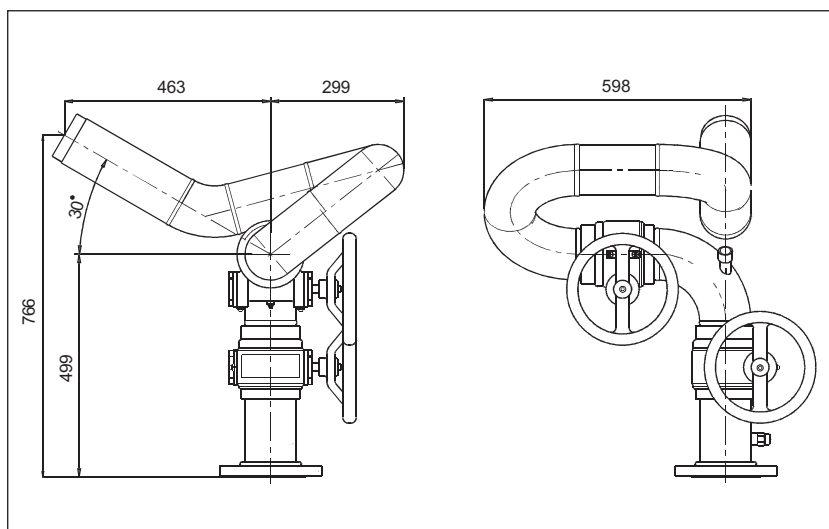

# Titan GMS45

Stainless Steel Fire Monitor Nominal flow 4,500 l/min

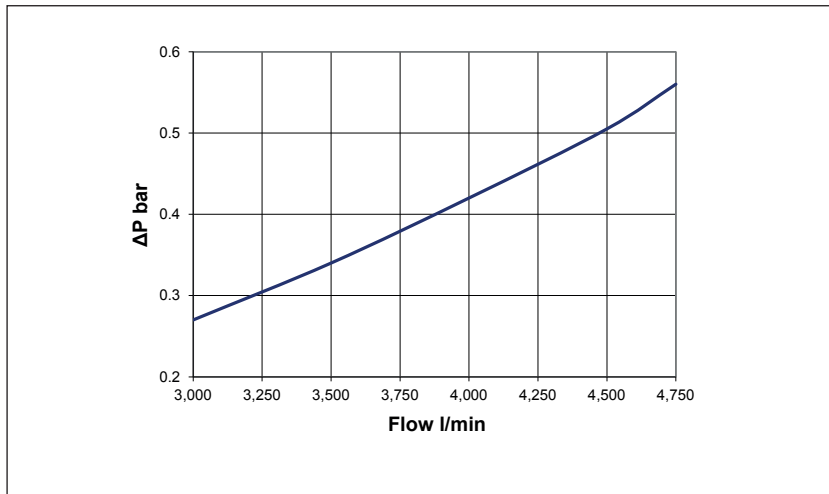

## Outlet nozzle options

Bronze bodies, manual controlled, fog/ jet nozzles with shut off:

FJ20: 2000 l/min

Bronze bodies, manual controlled, fog/ jet nozzles:

FJ 1300 to 5000 l/min

Stainless steel barrel with bronze base, aspirating foam cannons:

FC 800 to 3000 l/min

Stainless steel water jet pipes:

WC 1500 and 3000 l/min

A range of dry powder nozzles is also available – refer to Angus Fire

All foam cannons come with the option of a manually operated spreader.

All nozzles and branchpipes come with the option of a self inducing foam connection.

(For technical details of nozzles and branchpipes see separate data sheets.)

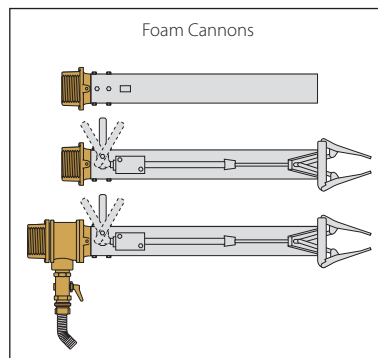
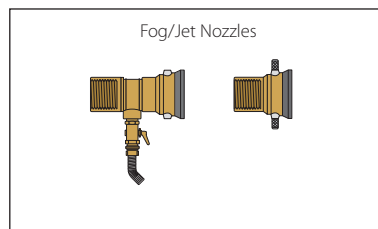

## Length and height of monitor water jet

FJ4000 nozzle at 11 bar monitor inlet pressure:

Flow 4920 l/min

Maximum jet throw at 32°, 86m

Maximum jet height at 75°, 50m

*Note: The jet throw depends on a number of variables such as wind direction, type and concentration of foam in the water and the condition of the monitor water ways and nozzle.*

*For throw and height calculations at different inlet pressures and flows and for different nozzles and angles refer to the Angus interactive electronic data sheet.*

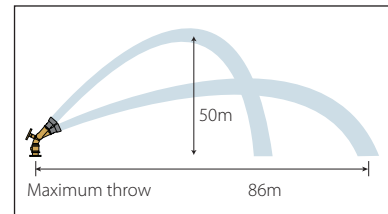

The Angus monitor range includes bronze models up to 8,500 l/min and stainless steel models up to 50,000 l/min.

Most models are available with lever or gearbox control, automatic oscillation or with hydraulic or electric remote control. All are suitable for use where explosive atmospheres may be present.

Angus is a company assessed to ISO 9001:2008

## INTERNATIONAL SALES

### Angus Fire Ltd

Angus House, Haddenham Business Park,  
Pegasus Way, Haddenham, Aylesbury, HP17 8LB, UK  
Tel: +44 (0)1844 293600 • Fax: +44 (0)1844 293664

## UK SALES

### Angus Fire Ltd

Station Road, Bentham, Lancaster, LA2 7NA, UK  
Tel: +44 (0)1524 264000 • Fax: +44 (0)1524 264180

Angus Fire operates a continuous programme of product development. The right is therefore reserved to modify any specification without prior notice and Angus Fire should be contacted to ensure that the current issues of all technical data sheets are used.