

6 Litre Triclass Foam Spray Gas Cartridge

Extinguisher



Technical Specification

Extinguisher Code	T6G
Extinguishant	Triclass Foam Spray
Propellant Type	55 gm Gas Cartridge
Capacity	6 Ltr
Paint Primer/Finish	Polyester Powder Paint
Paint Colour	Signal Red (RAL 3000)
Colour Coding to BS7863	Pale Cream (RAL 1014)
Fire Class	A, B Types + Electrical
Fire Rating	21A/144B
Operating Temperature	+5 to +60°C
Test Pressure	26 Bar
Operating Pressure at 20°C	12.5 Bar
Discharge Duration	40 sec
Discharge Range	4 m
Cylinder	Mild Steel 1.6mm to EN 10111-DD12
Operating Valve	Diecast Zinc Alloy to EN 1774-Zn A14 (ZL3)
Cylinder Lining	Polymer
Height	525 mm
Diameter	165 mm
Full Weight	11.40 kg
Empty Weight (excluding cartridge)	5.0 kg
Nominal Carton Size	170 x 170 x 540 mm
Approval	BS EN 3/BAFE



Spare Parts

Item	Description	Part No
1	Headcap assembly c/w hose and pick-up tube	MBRH 1030
2	Headcap 'O' ring seal	MBRH 0230
3	Safety pin	MBRH 0180
4	Safety pin cap	MBRH 0165
5	Break Tie Indicator	XE 18798
6	Service indicator	MBRH 0185
7	75g cartridge	MC75
-	Wall bracket (not shown)	MBRH 0195
-	Transport bracket and strap (not shown)	MBRH 0311
-	Triclass foam charge	MXF 001

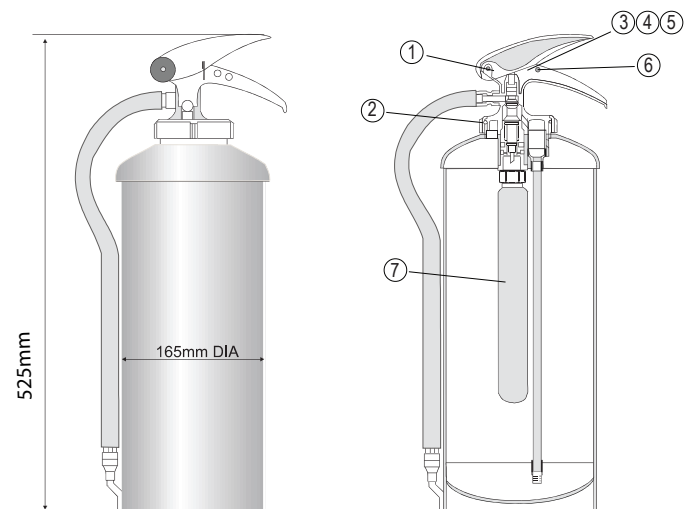

Angus Fire Ltd
Station Road,
Bentham, Lancaster, LA2 7NA
UK

Tel: +44 (0)1524 264000 • Fax: +44 (0)1524 264180

Email: general.enquiries@angusuk.co.uk • Web: www.angusfire.co.uk

Angus Fire operates a continuous programme of product development. The right is therefore reserved to modify any specification without prior notice and Angus Fire should be contacted to ensure that the current issues of all technical data sheets are used.

© Angus Fire
5293/4 04.19